

POWERMASTER

INSTRUCTION MANUAL

SPRING BALANCER

SEW – 140 / 170 / 200





WARNING

READ THIS INSTRUCTION MANUAL BEFORE USE

SAFETY ALERT SYMBOL AND ALERT SIGNS

The **SAFETY ALERT SYMBOL** () , **WARNING**, **CAUTION**, and **NOTE** carry special messages.

 This SAFETY ALERT SYMBOL is used to call your attention to items or operations that could be dangerous to you or other persons using this equipment. Please read these messages and follow these instructions carefully.
 WARNING: WARNING indicates a hazardous situation, which, if not avoided could result in death or serious injury.
 CAUTION: CAUTION indicates a hazardous situation, which, if not avoided could result in minor or moderate injury, damage or destruction of the equipment and others.
NOTE: NOTE indicates a special instruction in operation or maintenance.

1. Specification

Model	Capacity range (kg)		Travel (m)	Mass (kg)
	Minimum	Maximum		
SEW-140	121	140	1.5	32
SEW-170	141	170	1.5	35
SEW-200	171	200	1.5	37

2. Balancer installation (Fig. 1)

WARNING

- Install the Balancer correctly. Incorrect installation could cause personal injury or damage to the balancer or other equipment.
- Always attach a secondary support cable or chain. It is required to protect personnel in case of failure of the top hook or the fittings.

- a. Prepare a fitting strong enough to handle the maximum capacity of the balancer.

NOTE: The fitting must have no opening as shown in fig.1 to prevent the balancer from disengaging when it swings.

- b. Attach the balancer to the fitting and check the balancer does not hit surrounding objects. Make the mounting height different for each balancer to avoid collision.
- c. Check the top hook can swivel freely.

- d. Prepare a secondary support cable or chain that can support the maximum capacity of the balancer.
- e. As shown in fig. 1, attach an end of the secondary support chain to the balancer body, and attach the other end to a separate fitting, which does not support the balancer.

NOTE: Leave some slack in the secondary support cable or chain to allow the balancer to rotate freely. The slack must be a suitable length so that the balancer will stop within 100 mm when falling in case of failure of the top hook or the fitting.

Fig. 1

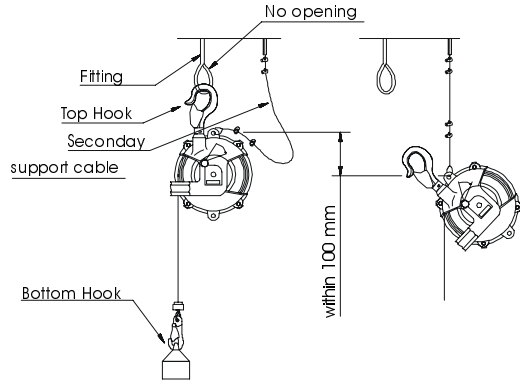
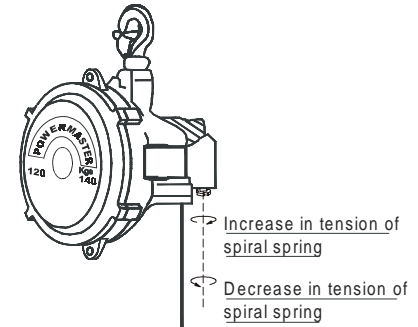

Fig. 2



3. Tool/device attachment, replacement and spring tension adjustment. (Fig. 1 & 2)

WARNING

It is very dangerous to attempt to replace any parts, without making sure that the pulley is locked. Lock the pulley using U-clamp over the wire rope assy.

- a. Before attaching, check the mass (weight) of the complete tool / device, including all accessories is within the capacity of the balancer.
- b. Adjust the spring tension by turning the worm drive. Turn clockwise for increasing the spring tension & counter-clockwise for reducing. New balancer is set at middle range before despatch from factory. (fig. 2)
- c. Attach the weight (tool/device) & release it slowly.

NOTE: *The suspended tool/device will drop down if the spring tension is not enough. Lower the tool/device slowly.*

- d. Adjust tensions for smooth operation. Remove limiting U-clamp and set at required position on wire rope assy.
- e. For replacement of any tool/device lift the weight to wind in the cable until pulley movement is stopped. The U-clamp over wire rope may be used to lock the movement.
- f. Replace the tool and readjust the spring tension to new weight. Very little effort is required to move the weight when adjusted.

NOTE: *Over tensioning could cause damage to the balancer spring.*

4. Use



WARNING

- *Never try to remove tool/device from the bottom hook while the wire rope is extended.*
- *Never stand under the suspended tool/device.*



CAUTION

- *Always use within the capacity range of the balancer and adjust the spring tension before use.*
- *Do not pull the wire rope at an angle.*

NOTE: *Adjust spring tension at regular interval as required. In case the spiral spring breaks, the stopper pin will pop out and lock the casing.*

5. Disassembly (Fig. C)



WARNING

* *A spiral spring is installed inside the balancer body. If the balancer is disassembled without care, the internal spring could pop out and cause personal injury.*

- a. Release all spring tension before disassembly by turning worm shaft (36) counter clockwise.
- b. Pull out wire rope (21) from drum pulley (50), and open the bolts (2) securing body casing.
- b. Take out the pulley (15) & spring assembly from body (23).
- c. Disassemble pulley (15) along with wire rope (21) from spring assembly (11).
- d. Open securing bolts (4) to remove bearing casing (5) from spring casing (11).

6. Assembly (Fig. C)

WARNING

* *Handle the spiral spring carefully. Never remove spiral spring from casing without proper tooling.*

- a. Fit bearing cover (5), using screws (4) over spring assy (11).
- b. Fit centre shaft (33) into the body. Fit worm gear (34) and secure the gear cover (37).
- c. Place pulley (15) over the spring casing (11) and slide both the items onto central shaft (33) inside the body.
- d. Place top cover (1) over body and secure with nuts (26) & bolts (2).
- e. Fit worm shaft (36) into gear casing (37). Fit & adjust the thrust pin (39).
- f. Check for smooth operation for complete range.
- g. Check for operation of safety lock pin (10) by reducing tension below minimum load capacity.

7. Inspection

Periodicity: -

Inspect balancer once a month. Make inspection period shorter when operating frequently or in hostile environment.

Procedure: -

- Visually inspect the assembly for general material state.
- Check both hooks for wear, damage and deformation.
- Check wire rope assembly for kinks, broken wires per pitch, wear & damages to thimble & other sub parts.
- Check pulley for wear, damage and distortion.
- Functionally check smooth operation of balancer for complete range.

ILLUSTRATED PART LIST

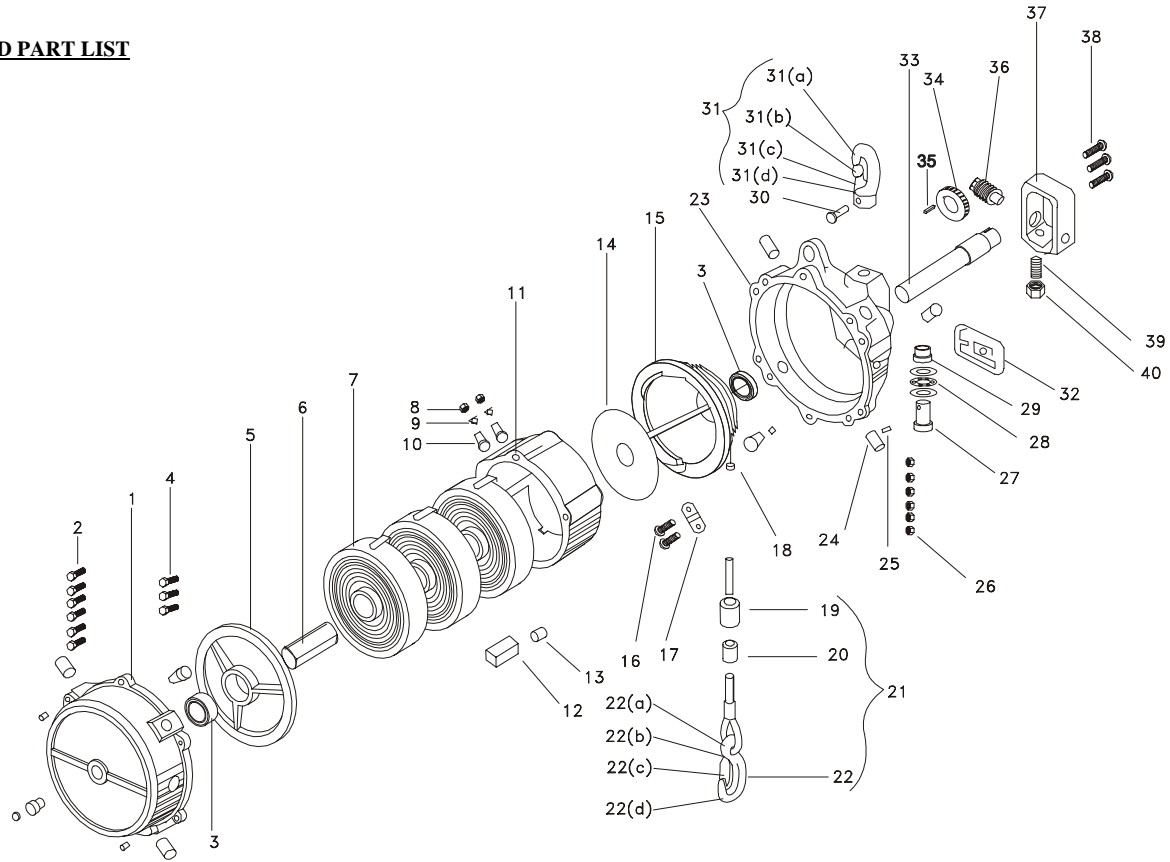

**Fig. C SPRING BALANCERS (SEW - 140/170/200)
AMENDMENT No. : 10/2001**

PART LIST FOR SEW - 140 / 170 / 200 SPRING BALANCERS

Item No.	Description	Qty
1	Cover, Body	1
2	Bolts	6
3	Bearing	2
4	Bolts, Bearing Cover	3
5	Bearing Cover	1
6	Sleeve, Springs	1
7	Spiral Spring	3/4
8	Nut, Safety Pin	2
9	Spring, Safety Pin	2
10	Safety Pin	2
11	Spring Casing	1
12	Stopper, Spring Casing	3
13	Pin	3
14	Plate	1
15	Drum Pulley	1
16	Hexagon Bolt	2

Item No.	Description	Qty
17	Stopper Plate, Wire Rope	1
18	Grub Screw	1
19	Buffer	1
20	Stopper For Buffer	1
21	Wire Rope Assy.	1
22	*Bottom Hook Assembly	1
22 (a)	**Hook	1
22 (b)	**Spring, Pin	1
22 (c)	**Spring, Safety Plate	1
22 (d)	**Rivet, Safety Plate	1
23	Main Body	1
24	Stopper Safety	8
25	Allen Screw For Stopper	8
26	Hexagon Nut	6
27	Shaft, Top Hook	1
28	Thrust Bearing	1

Item No.	Description	Qty
29	Bush, Hook Shaft	1
30	Rivet, Top Hook	1
31	Top Hook Assey.	1
31 (a)	*Hook	1
31 (b)	*Safety Plate	1
31 (c)	*Spring, Safety Plate	1
31 (d)	*Rivet, Safety Plate	1
32	Packing	1
33	Centre Shaft	1
34	Worm gear	1
35	Key	1
36	Worm Shaft	1
37	Casing, Worm Gear	1
38	Allen Screws	3
39	Thrust Pin	1
40	Hexagon Lock Nut	1

*- Sub Assembly

**- Sub Sub-Assembly

NOTE:- For demanding spares please give complete details of item e.g. Body Cover for SEW-140, Fig. C, Item No 1.

Amendment:- 10/2001

POWERMASTER INDUSTRIAL EQUIPMENTS PVT. LTD.

MUMBAI – 400 011, INDIA.

Website :- www.tubeexpander.com

E-mail :- mailbox@tubeexpander.com